

W39V040FB Data Sheet



512K × 8 CMOS FLASH MEMORY WITH FWH INTERFACE

Table of Contents-

1.	GENERAL DESCRIPTION	3
2.	FEATURES	3
3.	PIN CONFIGURATIONS	4
4.	BLOCK DIAGRAM	4
5.	PIN DESCRIPTION.....	4
6.	FUNCTIONAL DESCRIPTION	5
6.1	Interface Mode Selection and Description.....	5
6.2	Read (Write) Mode	5
6.3	Reset Operation.....	5
6.4	Boot Block Operation and Hardware Protection at Initial- #TBL & #WP.....	5
6.5	Sector Erase Command	6
6.6	Program Operation	6
6.7	Hardware Data Protection	6
6.8	WRITE OPERATION STATUS.....	6
7.	REGISTER FOR FWH MODE	8
7.1	General Purpose Inputs Register for FWH Mode.....	8
7.2	Product Identification Registers.....	8
7.3	Block Locking Registers	8
7.4	Register Based Block Locking Value Definitions Table	9
7.5	Read Lock.....	10
7.6	Write Lock.....	10
7.7	Lock Down	10
7.8	Product Identification Registers.....	10
8.	TABLE OF OPERATING MODES	11
8.1	Operating Mode Selection - Programmer Mode.....	11
8.2	Operating Mode Selection - FWH Mode	11
8.3	FWH Cycle Definition.....	11
9.	TABLE OF COMMAND DEFINITION	12
9.1	Embedded Programming Algorithm	13
9.2	Embedded Erase Algorithm.....	14
9.3	Embedded #Data Polling Algorithm.....	15
9.4	Embedded Toggle Bit Algorithm.....	16
9.5	Software Product Identification and Boot Block Lockout Detection Acquisition Flow .	17



10.	ELECTRICAL CHARACTERISTICS.....	18
10.1	Absolute Maximum Ratings.....	18
10.2	Programmer interface Mode DC Operating Characteristics.....	18
10.3	FWH Interface Mode DC Operating Characteristics	19
10.4	Power-up Timing.....	19
10.5	Capacitance.....	19
10.6	Programmer Interface Mode AC Characteristics.....	20
10.7	Read Cycle Timing Parameters.....	21
10.8	Write Cycle Timing Parameters.....	21
10.9	Data Polling and Toggle Bit Timing Parameters	21
11.	TIMING WAVEFORMS FOR PROGRAMMER INTERFACE MODE	22
11.1	Read Cycle Timing Diagram.....	22
11.2	Write Cycle Timing Diagram.....	22
11.3	Program Cycle Timing Diagram	23
11.4	#DATA Polling Timing Diagram.....	23
11.5	Toggle Bit Timing Diagram	24
11.6	Sector Erase Timing Diagram	24
12.	FWH INTERFACE MODE AC CHARACTERISTICS	25
12.1	AC Test Conditions.....	25
12.2	Read/Write Cycle Timing Parameters	25
12.3	Reset Timing Parameters.....	25
13.	TIMING WAVEFORMS FOR FWH INTERFACE MODE.....	26
13.1	Read Cycle Timing Diagram.....	26
13.2	Write Cycle Timing Diagram.....	26
13.3	Program Cycle Timing Diagram	27
13.4	#DATA Polling Timing Diagram.....	28
13.5	Toggle Bit Timing Diagram	29
13.6	FGPI Register/Product ID Readout Timing Diagram.....	31
13.7	Reset Timing Diagram.....	31
14.	ORDERING INFORMATION	32
15.	HOW TO READ THE TOP MARKING.....	32
16.	PACKAGE DIMENSIONS.....	33
16.1	32L PLCC	33
16.2	32L STSOP.....	33
17.	VERSION HISTORY	34



1. GENERAL DESCRIPTION

The W39V040FB is a 4-megabit, 3.3-volt only CMOS flash memory organized as 512K × 8 bits. For flexible erase capability, the 4Mbits of data are divided into 8 uniform sectors of 64 Kbytes. The device can be programmed and erased in-system with a standard 3.3V power supply. A 12-volt VPP is required for accelerated program. The unique cell architecture of the W39V040FB results in fast program/erase operations with extremely low current consumption. This device can operate at two modes, Programmer bus interface mode, Firmware Hub (FWH) bus interface mode. As in the Programmer interface mode, it acts like the traditional flash but with a multiplexed address inputs. But in the FWH interface mode, this device complies with the Intel FWH specification. The device can also be programmed and erased using standard EPROM programmers.

2. FEATURES

- Single 3.3-volt operations:
 - 3.3-volt Read
 - 3.3-volt Erase
 - 3.3-volt Program
- Fast Program operation:
 - Byte-by-Byte programming: 9 μS (typ.) (VPP = 12V)
 - Byte-by-Byte programming: 12 μS (typ.) (VPP = Vcc)
- Fast Erase operation:
 - Sector erase 0.6 Sec. (typ.)
- Fast Read access time: T_{kq} 11 nS
- Endurance: 10K cycles (typ.)
- Twenty-year data retention
- 8 Even sectors with 64K bytes
- Any individual sector can be erased
- Hardware protection:
 - #TBL supports 64-Kbyte Boot Block hardware protection
 - #WP supports the whole chip except Boot Block hardware protection
- Low power consumption
 - Active current: 15 mA (typ. for FWH read mode)
- Automatic program and erase timing with internal VPP generation
- End of program or erase detection
 - Toggle bit
 - Data polling
- Latched address and data
- TTL compatible I/O
- Available packages: 32L PLCC, 32L STSOP
32L PLCC Lead free, 32L STSOP Lead free



3. PIN CONFIGURATIONS

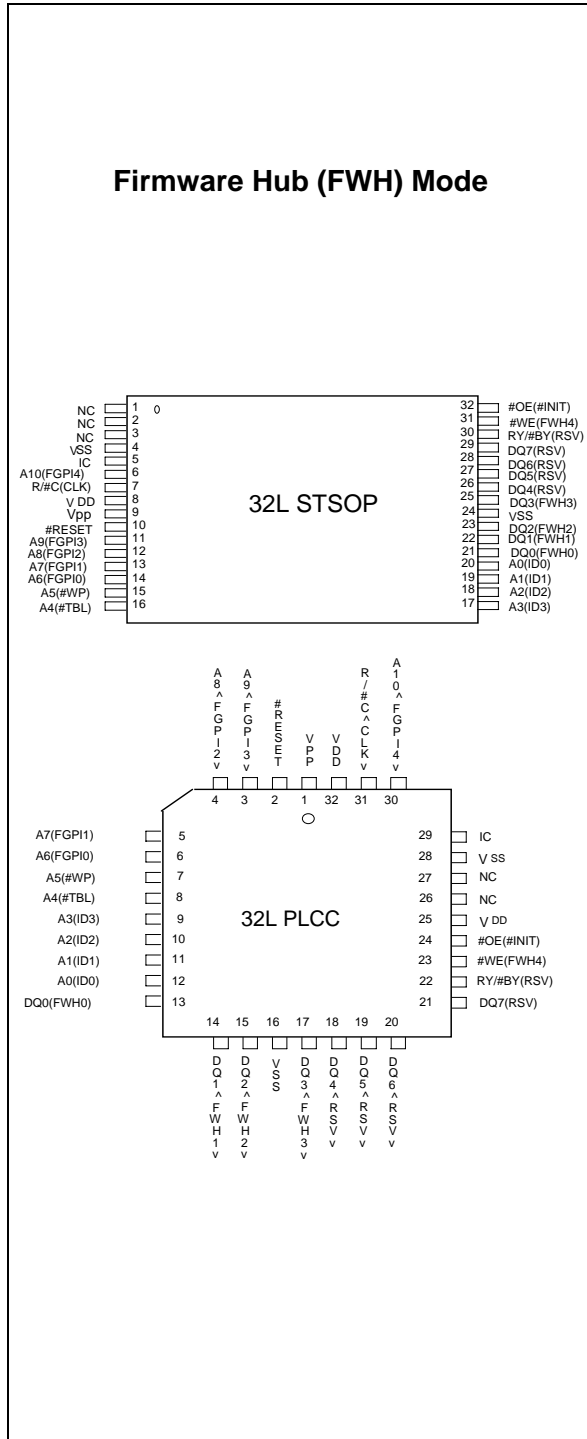

4. BLOCK DIAGRAM

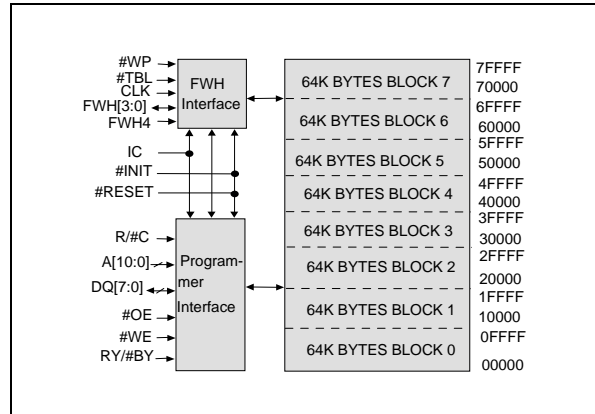

5. PIN DESCRIPTION

SYM.	INTERFACE		PIN NAME
	PGM	FWH	
IC	*	*	Interface Mode Selection
#RESET	*	*	Reset
#INIT		*	Initialize
#TBL		*	Top Boot Block Lock
#WP		*	Write Protect
CLK		*	CLK Input
FGPI[4:0]		*	General Purpose Inputs
ID[3:0]		*	Identification Inputs They Are Internal Pull Down to Vss
FWH[3:0]		*	Address/Data Inputs
FWH4		*	FWH Cycle Initial
R#C	*		Row/Column Select
A[10:0]	*		Address Inputs
DQ[7:0]	*		Data Inputs/Outputs
#OE	*		Output Enable
#WE	*		Write Enable
RY/#BY	*		Ready/ Busy
VDD	*	*	Power Supply
Vss	*	*	Ground
VPP	*	*	Accelerate Program Power Supply
RSV	*	*	Reserved Pins
NC	*	*	No Connection



6. FUNCTIONAL DESCRIPTION

6.1 Interface Mode Selection and Description

This device can operate in two interface modes, one is Programmer interface mode, and the other is FWH interface mode. The IC (Mode) pin of the device provides the control between these two interface modes. These interface modes need to be configured before power up or return from #RESET. When IC (Mode) pin is set to VDD, the device will be in the Programmer mode; while the IC (Mode) pin is set to low state (or leaved no connection), it will be in the FWH mode. In Programmer mode, this device just behaves like traditional flash parts with 8 data lines. But the row and column address inputs are multiplexed. The row address are mapped to the higher internal address A[18:11]. And the column address are mapped to the lower internal address A[10:0]. For FWH mode, it complies with the FWH Interface Specification, through the FWH[3:0] to communicate with the system chipset .

6.2 Read (Write) Mode

In Programmer interface mode, the read (write) operation of the W39V040FB is controlled by #OE (#WE). The #OE (#WE) is held low for the host to obtain (write) data from (to) the outputs (inputs). #OE is the output control and is used to gate data from the output pins. The data bus is in high impedance state when #OE is high. As for in the FWH interface mode, the read or write is determined by the "bit 0 & bit 1 of START CYCLE ". Refer to the FWH cycle definition and timing waveforms for further details.

6.3 Reset Operation

The #RESET input pin can be used in some application. When #RESET pin is at high state, the device is in normal operation mode. When #RESET pin is at low state, it will halt the device and all outputs will be at high impedance state. As the high state re-asserted to the #RESET pin, the device will return to read or standby mode, it depends on the control signals.

6.4 Boot Block Operation and Hardware Protection at Initial- #TBL & #WP

There is a hardware method to protect the top boot block and other sectors. Before power on programmer, tie the #TBL pin to low state and then the top boot block will not be programmed/erased. If #WP pin is tied to low state before power on, the other sectors will not be programmed/erased.

In order to detect whether the boot block feature is set on or not, users can perform software command sequence: enter the product identification mode (see Command Codes for Identification/Boot Block Lockout Detection for specific code), and then read from address 7FFF2(hex). You can check the DQ2/DQ3 at the address 7FFF2 to see whether the #TBL/#WP pin is in low or high state. If the DQ2 is "0", it means the #TBL pin is tied to high state. In such condition, whether boot block can be programmed/erased or not will depend on software setting. On the other hand, if the DQ2 is "1", it means the #TBL pin is tied to low state, then boot block is locked no matter how the software is set. Like the DQ2, the DQ3 inversely mirrors the #WP state. If the DQ3 is "0", it means the #WP pin is in high state, then all the sectors except the boot block can be programmed/erased. On the other hand, if the DQ3 is "1", then all the sectors except the boot block are programmed/erased inhibited.



To return to normal operation, perform a three-byte command sequence (or an alternate single-byte command) to exit the identification mode. For the specific code, see Command Codes for Identification/Boot Block Lockout Detection.

6.5 Sector Erase Command

Sector erase is a six-bus cycles operation. There are two "unlock" write cycles, followed by writing the "set-up" command. Two more "unlock" write cycles then follows by the Sector erase command. The Sector address (any address location within the desired Sector) is latched on the rising edge of R/#C in programmer mode, while the command (30H) is latched on the rising edge of #WE.

Sector erase does not require the user to program the device prior to erase. When erasing a Sector, the remaining unselected sectors are not affected. The system is not required to provide any controls or timings during these operations.

The automatic Sector erase begins after the erase command is completed, right from the rising edge of the #WE pulse for the last Sector erase command pulse and terminates when the data on DQ7, Data Polling, is "1" at which time the device returns to the read mode. Data Polling must be performed at an address within any of the sectors being erased.

Refer to the Erase Command flow Chart using typical command strings and bus operations.

6.6 Program Operation

The W39V040FB is programmed on a byte-by-byte basis. Program operation can only change logical data "1" to logical data "0." The erase operation, which changed entire data in main memory and/or boot block from "0" to "1", is needed before programming.

The program operation is initiated by a 4-byte command cycle (see Command Codes for Byte Programming). The device will internally enter the program operation immediately after the byte-program command is entered. The internal program timer will automatically time-out (12 μ S typ. - TBP) once it is completed and then return to normal read mode. Data polling and/or Toggle Bits can be used to detect end of program cycle.

6.7 Hardware Data Protection

The integrity of the data stored in the W39V040FB is also hardware protected in the following ways:

- (1) Noise/Glitch Protection: A #WE pulse of less than 5 nS in duration will not initiate a write cycle.
- (2) VDD Power Up/Down Detection: The programming and read operation are inhibited when VDD is less than 2.0V typical.
- (3) Write Inhibit Mode: Forcing #OE low or #WE high will inhibit the write operation. This prevents inadvertent writes during power-up or power-down periods.

6.8 WRITE OPERATION STATUS

The device provides several bits to determine the status of a program or erase operation: DQ5, DQ6, and DQ7. Each of DQ7 and DQ6 provides a method for determining whether a program or erase operation is complete or in progress. The device also offers a hardware-based output signal, RY/#BY in programmer mode, to determine whether an Embedded Program or Erase operation is in progress or has been completed.

**DQ7: #Data Polling**

The #Data Polling bit, DQ7, indicates whether an Embedded Program or Erase algorithm is in progress or completed. Data Polling is valid after the rising edge of the final #WE pulse in the command sequence.

During the Embedded Program algorithm, the device outputs on DQ7 and the complement of the data programmed to DQ7. Once the Embedded Program algorithm has completed, the device outputs the data programmed to DQ7. The system must provide the program address to read valid status information on DQ7. If a program address falls within a protected sector, #Data Polling on DQ7 is active for about 1 μ S, and then the device returns to the read mode.

During the Embedded Erase algorithm, #Data Polling produces "0" on DQ7. Once the Embedded Erase algorithm has completed, #Data Polling produces "1" on DQ7. An address within any of the sectors selected for erasure must be provided to read valid status information on DQ7.

Just before the completion of an Embedded Program or Erase operation, DQ7 may change asynchronously with DQ0-DQ6 while Output Enable (#OE) is set to low. That is, the device may change from providing status information to valid data on DQ7. Depending on when it samples the DQ7 output, the system may read the status or valid data. Even if the device has completed the program or erase operation and DQ7 has valid data, the data outputs on DQ0-DQ6 may be still invalid. Valid data on DQ7-DQ0 will appear on successive read cycles.

RY/#BY: Ready/#Busy

The RY/#BY is a dedicated, open-drain output pin which indicates whether an Embedded Algorithm is in progress or complete. The RY/#BY status is valid after the rising edge of the final #WE pulse in the command sequence. Since RY/#BY is an open-drain output, several RY/#BY pins can be tied together in parallel with a pull-up resistor to V_{DD} .

When the output is low (Busy), the device is actively erasing or programming. When the output is high (Ready), the device is in the read mode or standby mode.

DQ6: Toggle Bit

Toggle Bit on DQ6 indicates whether an Embedded Program or Erase algorithm is in progress or complete. Toggle Bit I may be read at any address, and is valid after the rising edge of the final #WE pulse in the command sequence (before the program or erase operation), and during the sector erase time-out.

During an Embedded Program or Erase algorithm operation, successive read cycles to any address cause DQ6 to toggle. The system may use either #OE or #CE to control the read cycles. Once the operation has completed, DQ6 stops toggling.

The system can use DQ6 to determine whether a sector is actively erasing. If the device is actively erasing (i.e., the Embedded Erase algorithm is in progress), DQ6 toggles. If a program address falls within a protected sector, DQ6 toggles for about 1 μ s after the program command sequence is written, and then returns to reading array data.

DQ5: Exceeded Timing Limits

DQ5 indicates whether the program or erase time has exceeded a specified internal pulse count limit. DQ5 produces "1" under these conditions which indicates that the program or erase cycle was not successfully completed.



The device may output “1” on DQ5 if the system tries to program “1” to a location that was previously programmed to “0.” Only the erase operation can change “0” back to “1.” Under this condition, the device stops the operation, and while the timing limit has been exceeded, DQ5 produces “1.”

Under both these conditions, the system must hardware reset to return to the read mode.

7. REGISTER FOR FWH MODE

There are three kinds of registers on this device, the General Purpose Input Registers, the Block Lock Control Registers and Product Identification Registers. Users can access these registers through respective address in the 4Gbytes memory map. There are detail descriptions in the sections below.

7.1 General Purpose Inputs Register for FWH Mode

This register reads the FGPI[4:0] pins on the W39V040FB. This is a pass-through register which can read via memory address FFBC0100(hex). Since it is pass-through register, there is no default value.

GPI Register Table

BIT	FUNCTION
7 – 5	Reserved
4	Read FGPI4 pin status
3	Read FGPI3 pin status
2	Read FGPI2 pin status
1	Read FGPI1 pin status
0	Read FGPI0 pin status

7.2 Product Identification Registers

In the FWH interface mode, a read from FFBC, 0000(hex) can output the manufacturer code, DA(hex). A read from FFBC, 0001(hex) can output the device code 54(hex).

There is an alternative software method to read out the Product Identification in both the Programmer interface mode and the FWH interface mode. Thus, the programming equipment can automatically matches the device with its proper erase and programming algorithms.

In the software access mode, a or JEDEC 3-byte command sequence can be used to access the product ID for programmer interface mode. A read from address 0000(hex) outputs the manufacturer code, DA(hex). A read from address 0001(hex) outputs the device code, 54(hex). The product ID operation can be terminated by a three-byte command sequence or an alternate one-byte command sequence (see Command Definition table for detail).

7.3 Block Locking Registers

This part provides 8 even 64Kbytes blocks, and each block can be locked by register control. These control registers can be set or clear through memory address. Below is the detail description.

Please note that this feature is only can be applied on FWH mode.



Block Locking Registers type and access memory map Table

REGISTERS	REGISTERS TYPE	CONTROL BLOCK	DEVICE PHYSICAL ADDRESS	4GBYTES SYSTEM MEMORY ADDRESS
BLR7	R/W	7	7FFFFh – 70000h	FFBF0002h
BLR6	R/W	6	6FFFFh – 60000h	FFBE0002h
BLR5	R/W	5	5FFFFh – 50000h	FFBD0002h
BLR4	R/W	4	4FFFFh – 40000h	FFBC0002h
BLR3	R/W	3	3FFFFh – 30000h	FFBB0002h
BLR2	R/W	2	2FFFFh – 20000h	FFBA0002h
BLR1	R/W	1	1FFFFh – 10000h	FFB90002h
BLR0	R/W	0	0FFFFh – 00000h	FFB80002h

Block Locking Register Bits Function Table

BIT	FUNCTION
7 – 3	Reserved
2	Read Lock 1: Prohibit to read in the block where set 0: Normal read operation in the block where clear. This is default state.
1	Lock Down 1: Prohibit further to set or clear the Read Lock or Write Lock bits. This Lock Down Bit can only be set not clear. Only the device is reset or re-powered, the Lock Down Bit is cleared. 0: Normal operation for Read Lock or Write Lock. This is the default state.
0	Write Lock 1: Prohibited to write in the block where set. This is default state. 0: Normal programming/erase operation in the block where clear.

7.4 Register Based Block Locking Value Definitions Table

BIT [7:3]	BIT 2	BIT 1	BIT 0	RESULT
00000	0	0	0	Full Access.
00000	0	0	1	Write Lock. Default State.
00000	0	1	0	Locked Open (Full Access, Lock Down).
00000	0	1	1	Write Locked, Locked Down.
00000	1	0	0	Read Locked.
00000	1	0	1	Read & Write Locked.
00000	1	1	0	Read Locked, Locked Down.
00000	1	1	1	Read & Write Locked, Locked Down.



7.5 Read Lock

Any attempt to read the data of read locked block will result in "00H." The default state of any block is unlocked upon power up. User can clear or set the write lock bit anytime as long as the lock down bit is not set.

7.6 Write Lock

This is the default state of blocks upon power up. Before any program or erase to the specified block, user should clear the write lock bit first. User can clear or set the write lock bit anytime as long as the lock down bit is not set. The write lock function is in conjunction with the hardware protect pins, #WP & TBL. When hardware protect pins are enabled, it will override the register block locking functions and write lock the blocks no matter how the status of the register bits. Reading the register bit will not reflect the status of the #WP or #TBL pins.

7.7 Lock Down

The default state of lock down bit for any block is unlocked. This bit can be set only once; any further attempt to set or clear is ignored. Only the reset from #RESET or #INIT can clear the lock down bit. Once the lock down bit is set for a block, then the write lock bit & read lock bit of that block will not be set or cleared, and keep its current state.

7.8 Product Identification Registers

In the FWH interface mode, a read from FFBC, 0000(hex) can output the manufacturer code, DA(hex). A read from FFBC,0001(hex) can output the device code 54(hex).

There is an alternative software method (six commands bytes) to read out the Product Identification in both the Programmer interface mode and the FWH interface mode. Thus, the programming equipment can automatically matches the device with its proper erase and programming algorithms.

In the software access mode, a six-byte (or JEDEC 3-byte) command sequence can be used to access the product ID for programmer interface mode. A read from address 0000(hex) outputs the manufacturer code, DA(hex). A read from address 0001(hex) outputs the device code, 54(hex). The product ID operation can be terminated by a three-byte command sequence or an alternate one-byte command sequence (see Command Definition table for detail).



8. TABLE OF OPERATING MODES

8.1 Operating Mode Selection - Programmer Mode

MODE	PINS				
	#OE	#WE	#RESET	ADDRESS	DQ.
Read	VIL	VIH	VIH	AIN	Dout
Write	VIH	VIL	VIH	AIN	Din
Standby	X	X	VIL	X	High Z
Write Inhibit	VIL	X	VIH	X	High Z/DOUT
	X	VIH	VIH	X	High Z/DOUT
Output Disable	VIH	X	VIH	X	High Z

8.2 Operating Mode Selection - FWH Mode

Operation modes in FWH interface mode are determined by "START Cycle" when it is selected. When it is not selected, its outputs (FWH[3:0]) will be disable. Please reference to the "FWH Cycle Definition".

8.3 FWH Cycle Definition

FIELD	NO. OF CLOCKS	DESCRIPTION
START	1	"1101b" indicates FWH Memory Read cycle; while "1110b" indicates FWH Memory Write cycle. "0000b" appears on FWH bus to indicate the initial
IDSEL	1	This one clock field indicates which FWH component is being selected.
MSIZE	1	Memory Size. There is always show "0000b" for single byte access.
TAR	2	Turned Around Time
ADDR	7	Address Phase for Memory Cycle. FWH supports the 28 bits address protocol. The addresses transfer most significant nibble first and least significant nibble last. (i.e. Address[27:24] on FWH[3:0] first, and Address[3:0] on FWH[3:0] last.)
SYNC	N	Synchronous to add wait state. "0000b" means Ready, "0101b" means Short Wait, "0110b" means Long Wait, "1001b" for DMA only, "1010b" means error, and other values are reserved.
DATA	2	Data Phase for Memory Cycle. The data transfer least significant nibble first and most significant nibble last. (i.e. DQ[3:0] on FWH[3:0] first, then DQ[7:4] on FWH[3:0] last.)



9. TABLE OF COMMAND DEFINITION

COMMAND DESCRIPTION	NO. OF Cycles (1)	1ST CYCLE	2ND CYCLE	3RD CYCLE	4TH CYCLE	5TH CYCLE	6TH CYCLE
		Addr. Data	Addr. Data	Addr. Data	Addr. Data	Addr. Data	Addr. Data
Read	1	A _{IN} D _{OUT}					
Sector Erase	6	5555 AA	2AAA 55	5555 80	5555 AA	2AAA 55	SA ⁽⁵⁾ 30
Byte Program	4	5555 AA	2AAA 55	5555 A0	A _{IN} D _{IN}		
Product ID Entry	3	5555 AA	2AAA 55	5555 90			
Product ID Exit ⁽⁴⁾	3	5555 AA	2AAA 55	5555 F0			
Product ID Exit ⁽⁴⁾	1	XXXX F0					

- Notes:**
1. The cycle means the write command cycle not the FWH clock cycle.
 2. The Column Address / Row Address are mapped to the Low / High order Internal Address. i.e. Column Address A[10:0] are mapped to the internal A[10:0], Row Address A[7:0] are mapped to the internal A[18:11]
 3. Address Format: A14–A0 (Hex); Data Format: DQ7-DQ0 (Hex)
 4. Either one of the two Product ID Exit commands can be used.
 5. SA: Sector Address

SA = 7XXXXh for Unique Sector7 (Boot Sector)	SA = 3XXXXh for Unique Sector3
SA = 6XXXXh for Unique Sector6	SA = 2XXXXh for Unique Sector2
SA = 5XXXXh for Unique Sector5	SA = 1XXXXh for Unique Sector1
SA = 4XXXXh for Unique Sector4	SA = 0XXXXh for Unique Sector0



9.1 Embedded Programming Algorithm

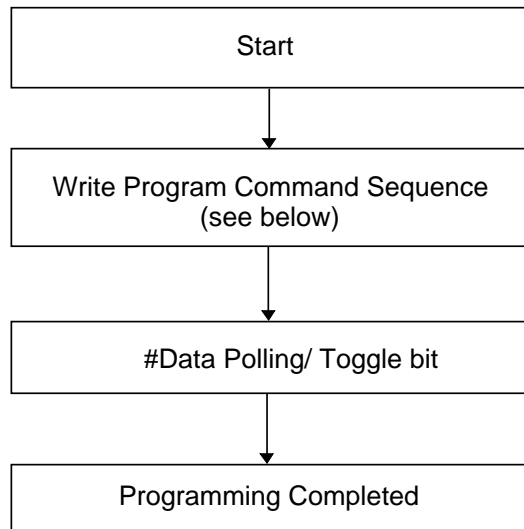

Program Command Sequence (Address/Command):

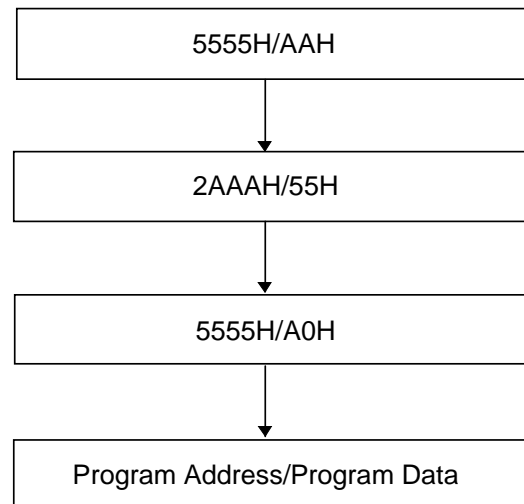



9.2 Embedded Erase Algorithm

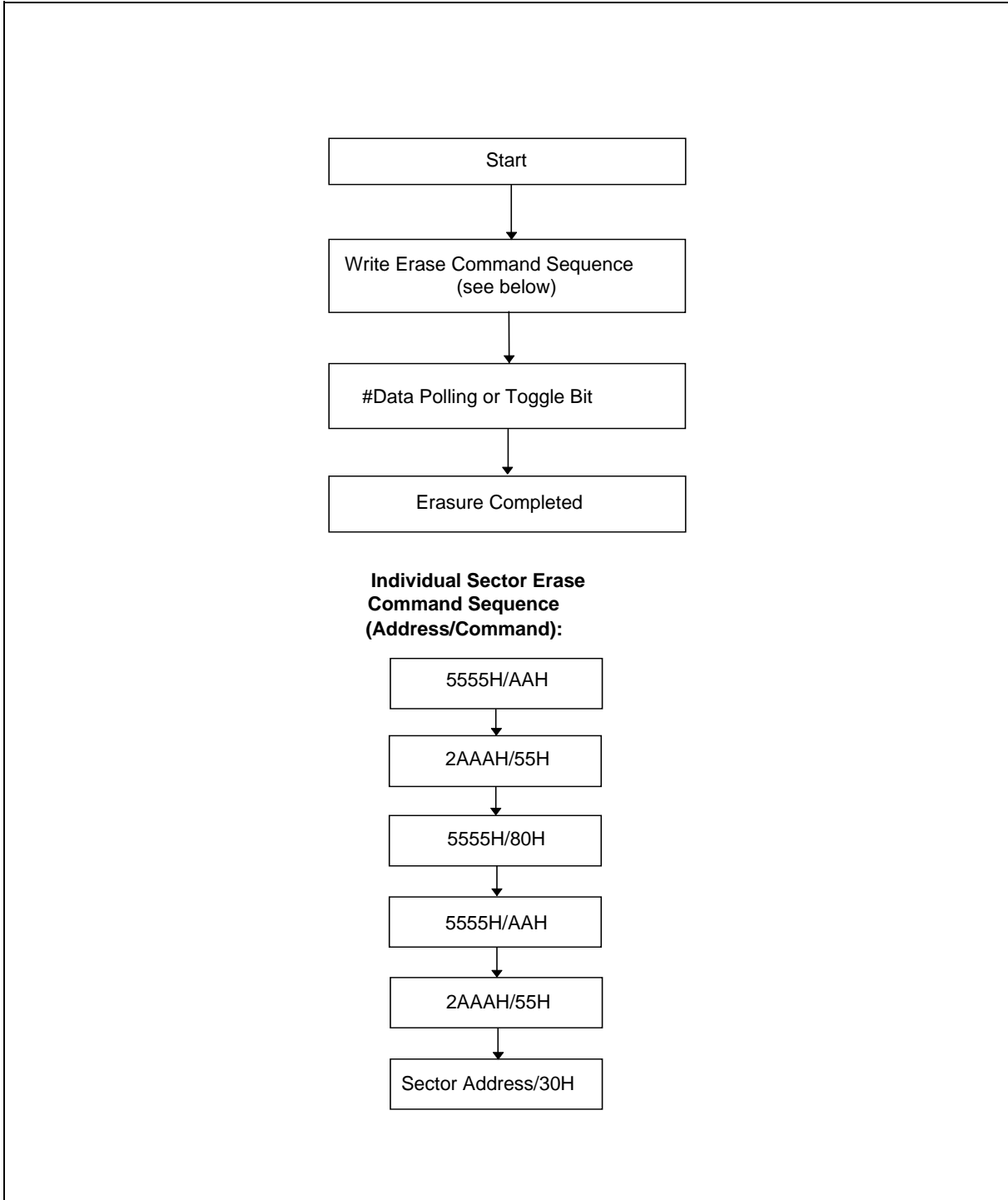



9.3 Embedded #Data Polling Algorithm

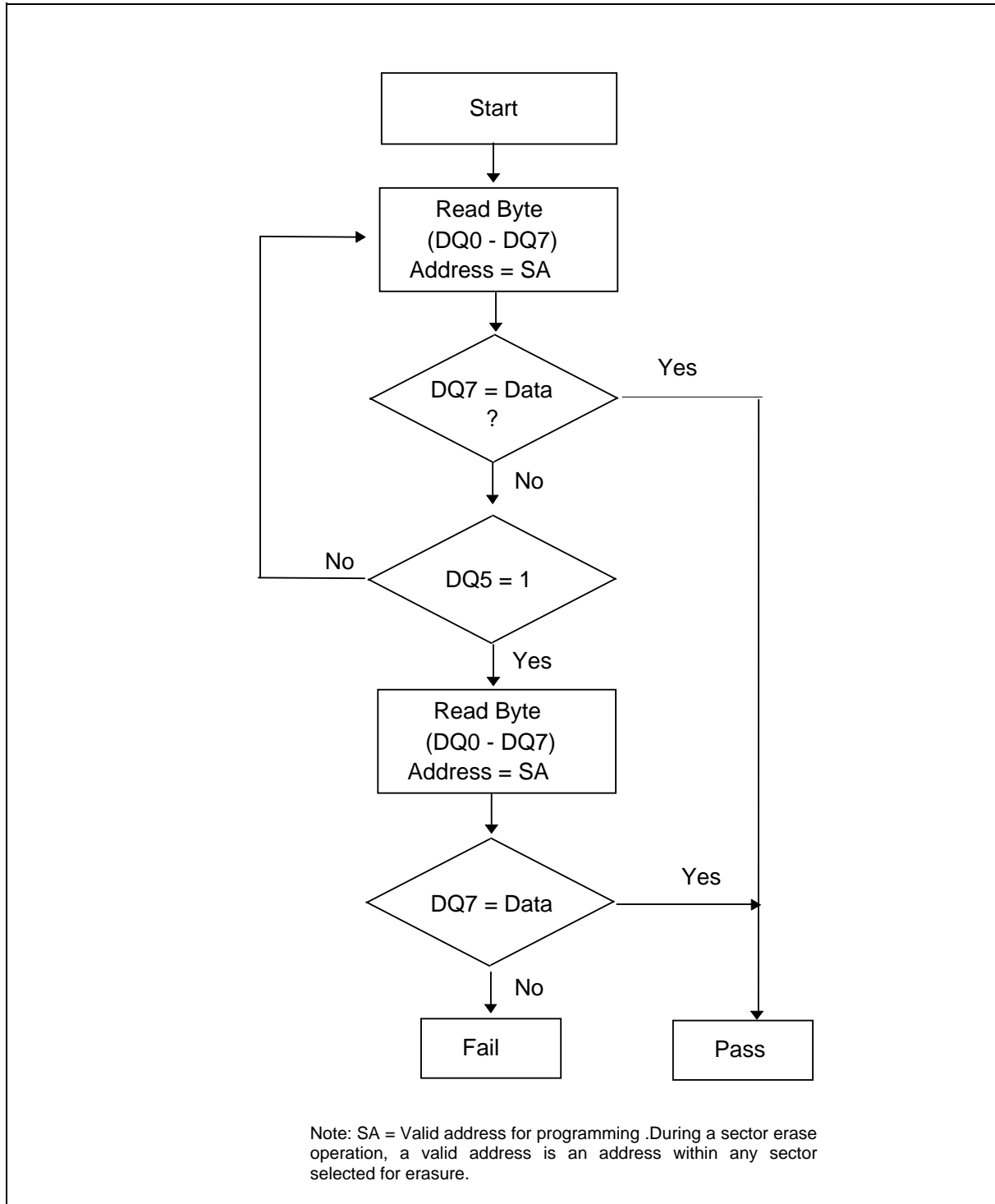



9.4 Embedded Toggle Bit Algorithm

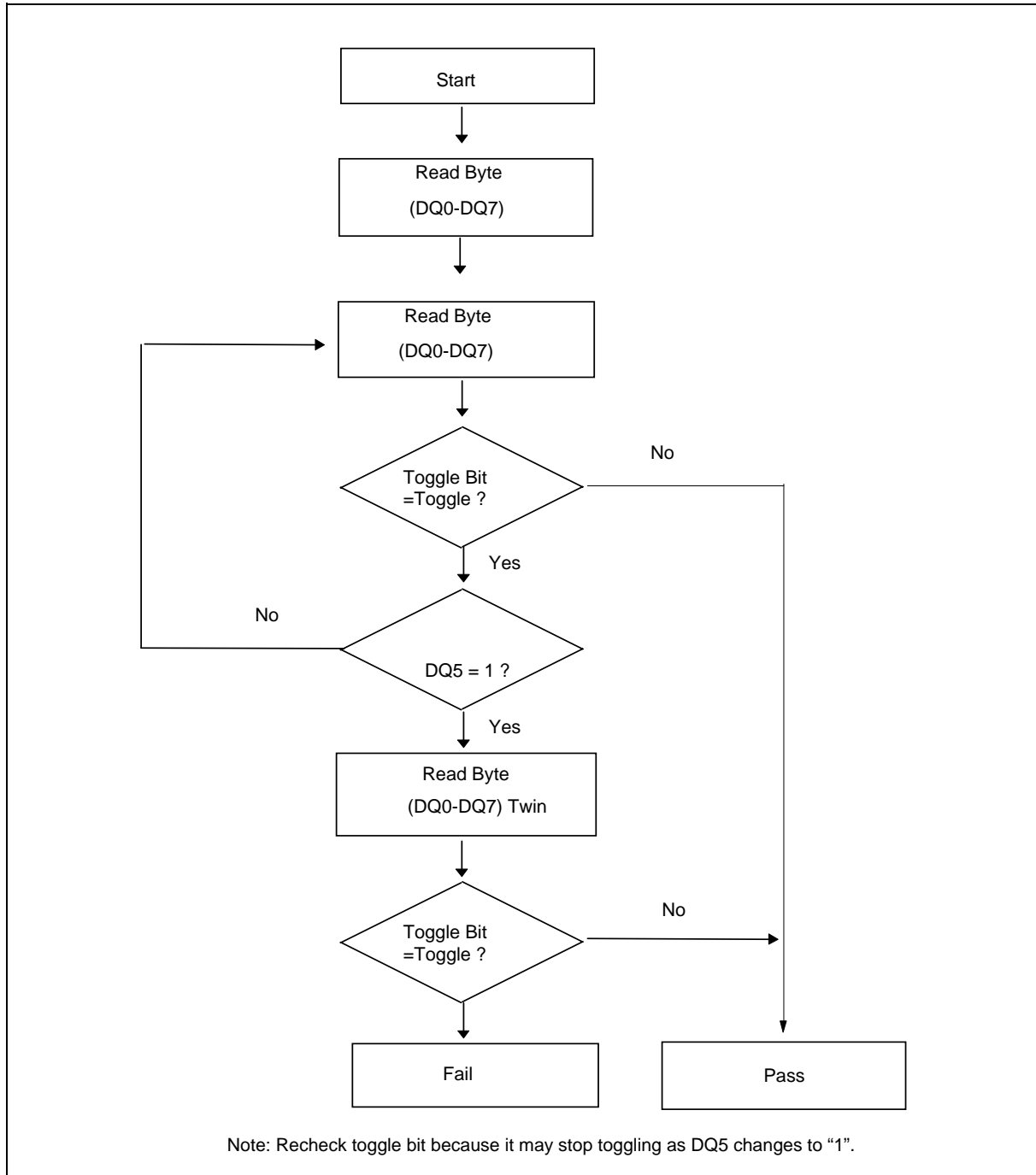



9.5 Software Product Identification and Boot Block Lockout Detection Acquisition Flow

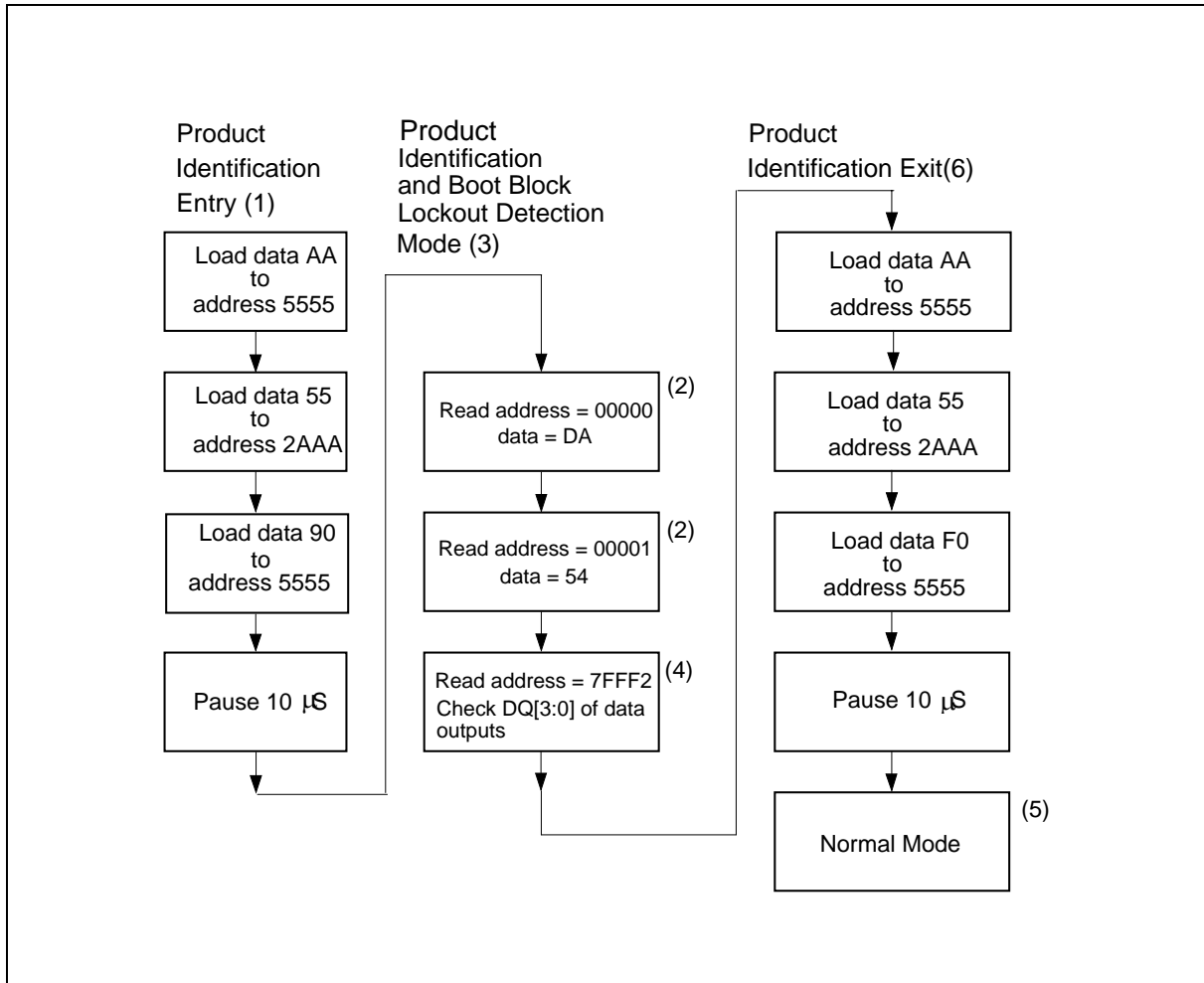

Notes for software product identification/boot block lockout detection:

- (1) Data Format: DQ7–DQ0 (Hex); Address Format: A14–A0 (Hex)
- (2) A1–A18 = V_{IL}; manufacture code is read for A0 = V_{IL}; device code is read for A0 = V_{IH}.
- (3) The device does not remain in identification and boot block lockout detection mode if power down.
- (4) The DQ[3:2] to indicate the sectors protect status as below:

	DQ2	DQ3
0	64Kbytes Boot Block Unlocked by #TBL hardware trapping	Whole Chip Unlocked by #WP hardware trapping Except Boot Block
1	64Kbytes Boot Block Locked by #TBL hardware trapping	Whole Chip Locked by #WP hardware trapping Except Boot Block

- (5) The device returns to standard operation mode.
- (6) Optional 1-write cycle (write F0 (hex.) at XXXX address) can be used to exit the product identification/boot block lockout detection.



10. ELECTRICAL CHARACTERISTICS

10.1 Absolute Maximum Ratings

PARAMETER	RATING	UNIT
Operating Temperature	0 to +70	°C
Storage Temperature	-65 to +150	°C
Power Supply Voltage to VSS Potential	-0.5 to +4.0	V
D.C. Voltage on Any Pin to Ground Potential	-0.5 to VDD +0.5	V
VPP Voltage	-0.5 to +13	V
Transient Voltage (<20 nS) on Any Pin to Ground Potential	-1.0 to VDD +0.5	V

Note: Exposure to conditions beyond those listed under Absolute Maximum Ratings May adversely affect the life and reliability of the device.

10.2 Programmer interface Mode DC Operating Characteristics

(VDD = 3.3V ± 0.3V, VSS= 0V, TA = 0 to 70° C)

PARAMETER	SYM.	TEST CONDITIONS	LIMITS			UNIT
			MIN.	TYP.	MAX.	
Power Supply Current	ICC	In Read or Write mode, all DQs open Address inputs = 3.0V/0V, at f = 3 MHz	-	15	30	mA
Input Leakage Current	ILI	VIN = VSS to VDD	-	-	90	μA
Output Leakage Current	ILO	VOUT = VSS to VDD	-	-	90	μA
Input Low Voltage	VIL	-	-0.5	-	0.8	V
Input High Voltage	VIH	-	2.0	-	VDD +0.5	V
Output Low Voltage	VOL	IOL = 2.1 mA	-	-	0.45	V
Output High Voltage	VOH	IOH = -0.1mA	2.4	-	-	V



10.3 FWH Interface Mode DC Operating Characteristics

(V_{DD} = 3.3V ± 0.3V, V_{SS} = 0V, T_A = 0 to 70° C)

PARAMETER	SYM.	TEST CONDITIONS	LIMITS			UNIT
			MIN.	TYP.	MAX.	
Power Supply Current Read	I _{CC}	All I _{out} = 0A, CLK = 33 MHz, in FWH mode operation.	-	15	25	mA
Power Supply Current Program/Erase	I _{CC}	CLK = 33 MHz, in FWH mode operation.	-	18	30	mA
Standby Current 1	I _{sb1}	FWH4 = 0.9 V _{DD} , CLK = 33 MHz, all inputs = 0.9 V _{DD} / 0.1 V _{DD} no internal operation	-	20	50	uA
Standby Current 2	I _{sb2}	FWH4 = 0.1 V _{DD} , CLK = 33 MHz, all inputs = 0.9 V _{DD} / 0.1 V _{DD} no internal operation.	-	3	10	mA
Input Low Voltage	V _{IL}	-	-0.5	-	0.3 V _{DD}	V
Input Low Voltage of #INIT	V _{ILI}	-	-0.5	-	0.2 V _{DD}	V
Input High Voltage	V _{IH}	-	0.5 V _{DD}	-	V _{DD} +0.5	V
Input High Voltage of #INIT Pin	V _{IHI}	-	1.35 V	-	V _{DD} +0.5	V
Output Low Voltage	V _{OL}	I _{OL} = 1.5 mA	-	-	0.1 V _{DD}	V
Output High Voltage	V _{OH}	I _{OH} = -0.5 mA	0.9 V _{DD}	-	-	V

10.4 Power-up Timing

PARAMETER	SYMBOL	TYPICAL	UNIT
Power-up to Read Operation	TPU. READ	100	μS
Power-up to Write Operation	TPU. WRITE	5	mS

10.5 Capacitance

(V_{DD} = 3.3V, T_A = 25° C, f = 1 MHz)

PARAMETER	SYMBOL	CONDITIONS	MAX.	UNIT
I/O Pin Capacitance	C _{I/O}	V _{I/O} = 0V	12	pf
Input Capacitance	C _{IN}	V _{IN} = 0V	6	pf



10.6 Programmer Interface Mode AC Characteristics

AC Test Conditions

PARAMETER	CONDITIONS
Input Pulse Levels	0V to 0.9 V _{DD}
Input Rise/Fall Time	< 5 nS
Input/Output Timing Level	1.5V/1.5V
Output Load	1 TTL Gate and C _L = 30 pF

AC Test Load and Waveform

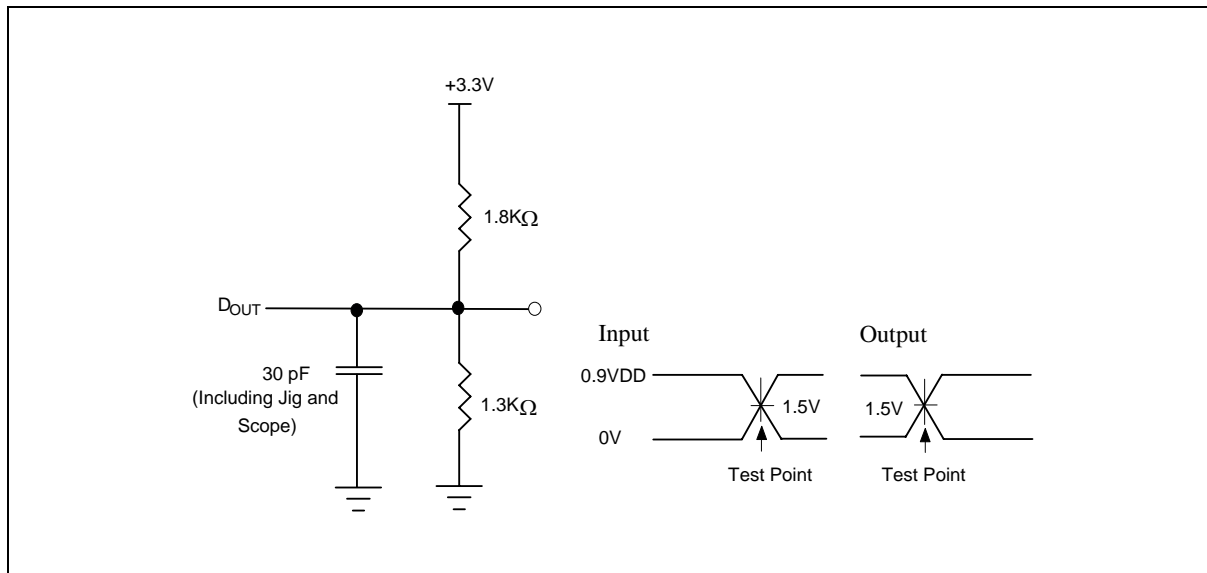



Programmer Interface Mode AC Characteristics, continued

10.7 Read Cycle Timing Parameters

(V_{DD} = 3.3V ± 0.3V, V_{SS} = 0V, T_A = 0 to 70° C)

PARAMETER	SYMBOL	W39V040FB		UNIT
		MIN.	MAX.	
Read Cycle Time	TRC	350	-	nS
Row / Column Address Set Up Time	TAS	50	-	nS
Row / Column Address Hold Time	TAH	50	-	nS
Address Access Time	TAA	-	150	nS
Output Enable Access Time	TOE	-	75	nS
#OE Low to Active Output	TOLZ	0	-	nS
#OE High to High-Z Output	TOHZ	-	35	nS
Output Hold from Address Change	TOH	0	-	nS

10.8 Write Cycle Timing Parameters

PARAMETER	SYMBOL	MIN.	TYP.	MAX.	UNIT
Reset Time	TRST	1	-	-	μS
Address Setup Time	TAS	50	-	-	nS
Address Hold Time	TAH	50	-	-	nS
R/#C to Write Enable High Time	TCWH	50	-	-	nS
#WE Pulse Width	TWP	100	-	-	nS
#WE High Width	TWPH	100	-	-	nS
Data Setup Time	TDS	50	-	-	nS
Data Hold Time	TDH	50	-	-	nS
#OE Hold Time	TOEH	0	-	-	nS
Byte programming Time	TBP	-	12	200	μS
Sector Erase Cycle Time (Note 2)	TPEC	-	0.6	6	S
Program/Erase Valid to RY/#BY Delay	TBUSY	90	-	-	nS

Notes: 1. All AC timing signals observe the following guidelines for determining setup and hold times:

(a) High level signal's reference level is input high and (b) low level signal's reference level is input low.
Ref. to the AC testing condition.

2. Exclude 00H pre-program prior to erasure. (In the pre-programming step of the embedded erase algorithm, all bytes are programmed to 00H before erasure)

10.9 Data Polling and Toggle Bit Timing Parameters

PARAMETER	SYMBOL	W39V040FB		UNIT
		MIN.	MAX.	
#OE to Data Polling Output Delay	TOEP	-	350	nS
#OE to Toggle Bit Output Delay	TOET	-	350	nS
Toggle or Polling interval	-	50	-	mS



11. TIMING WAVEFORMS FOR PROGRAMMER INTERFACE MODE

11.1 Read Cycle Timing Diagram

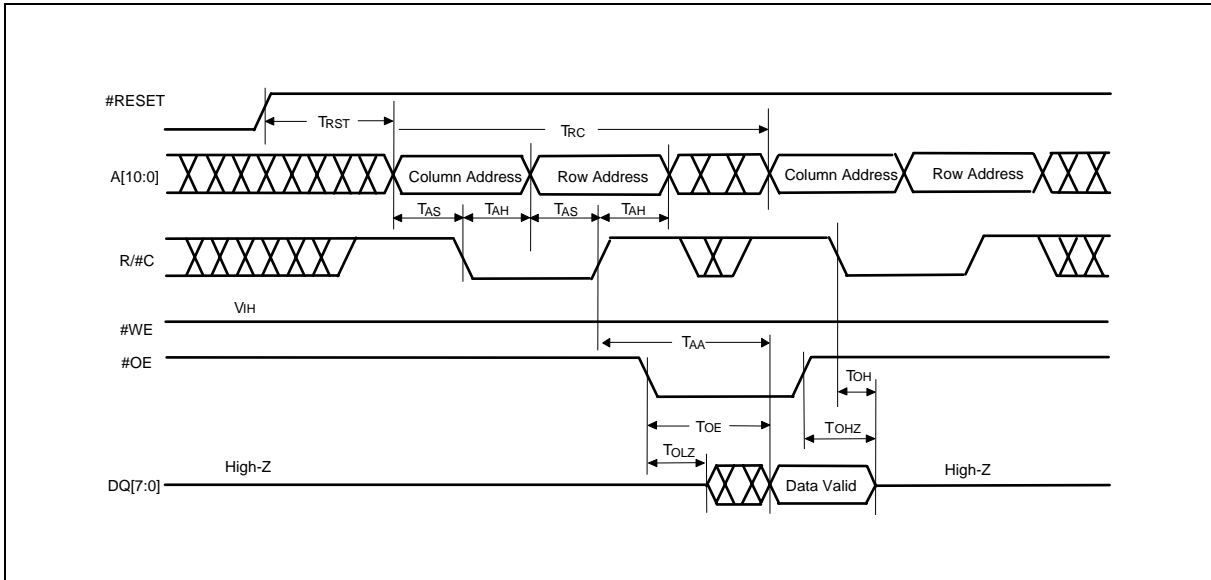

11.2 Write Cycle Timing Diagram

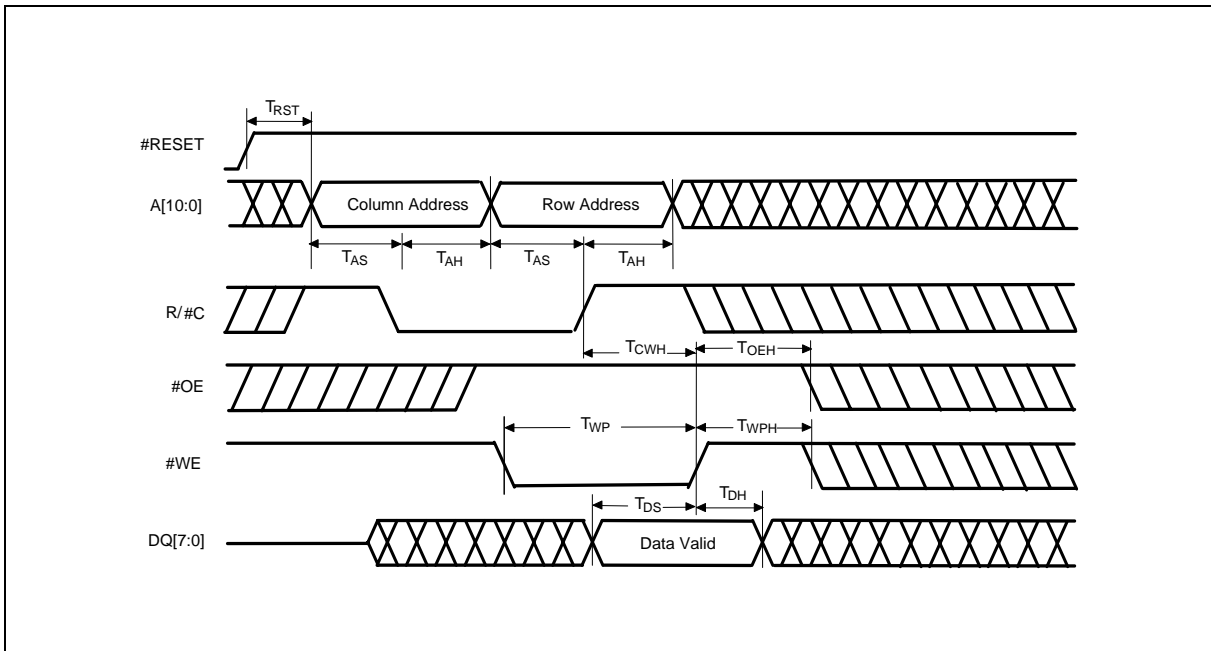



Timing Waveforms for Programmer Interface Mode, continued

11.3 Program Cycle Timing Diagram

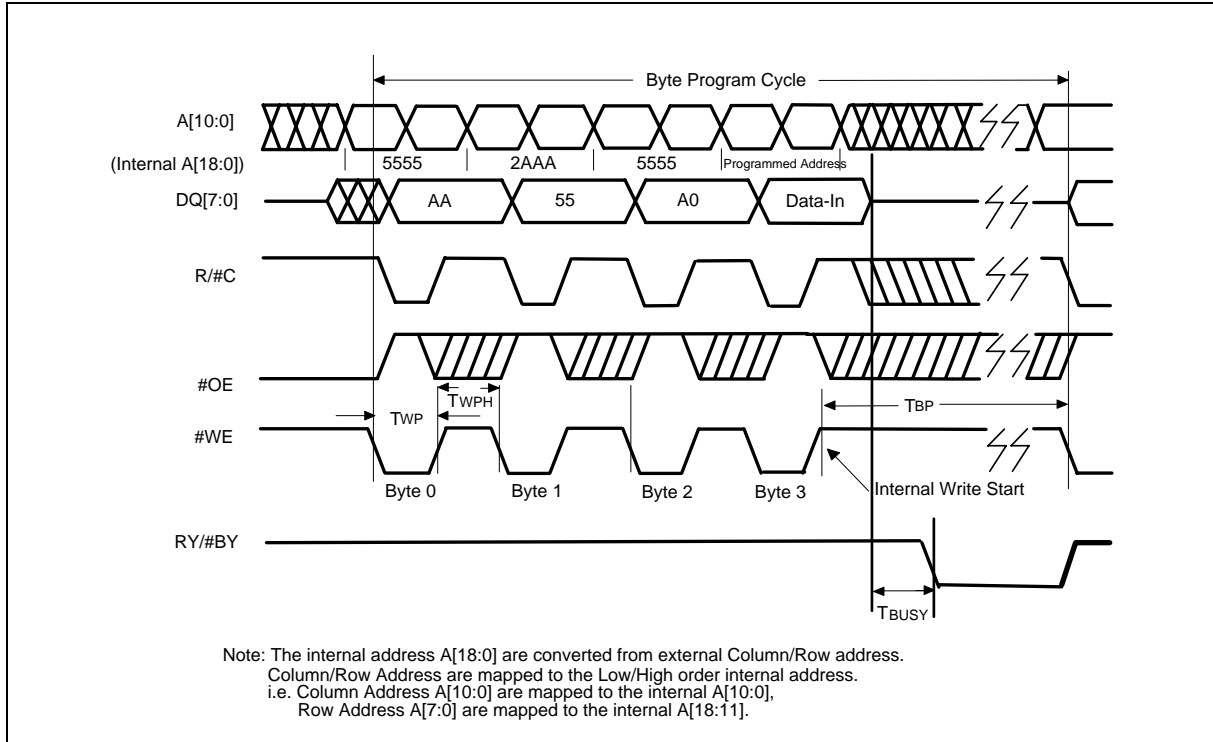

11.4 #DATA Polling Timing Diagram

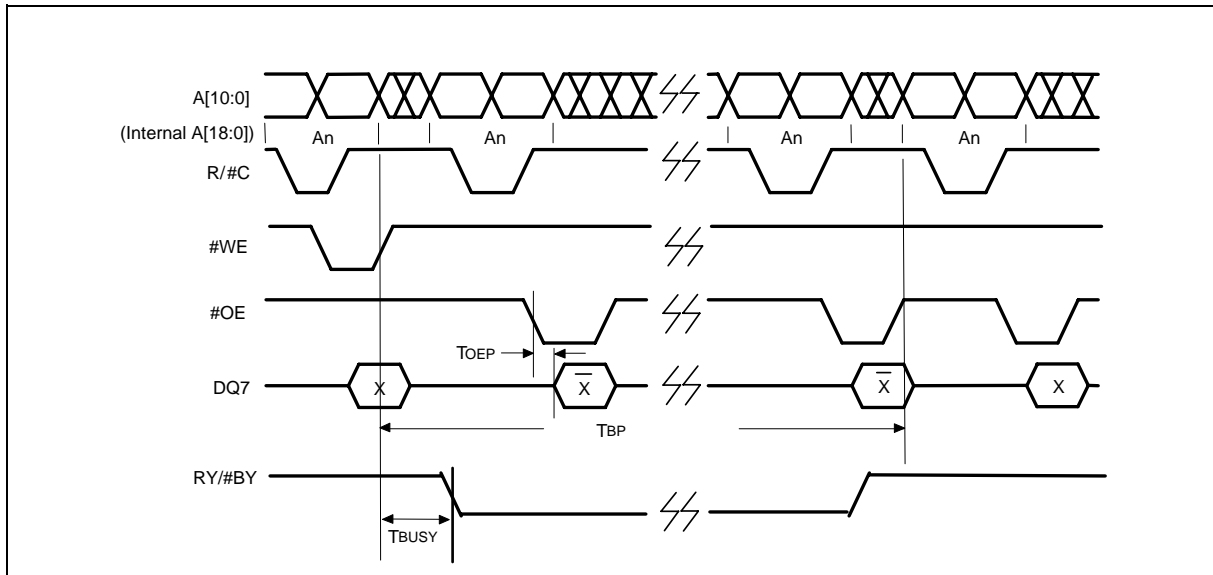



Timing Waveforms for Programmer Interface Mode, continued

11.5 Toggle Bit Timing Diagram

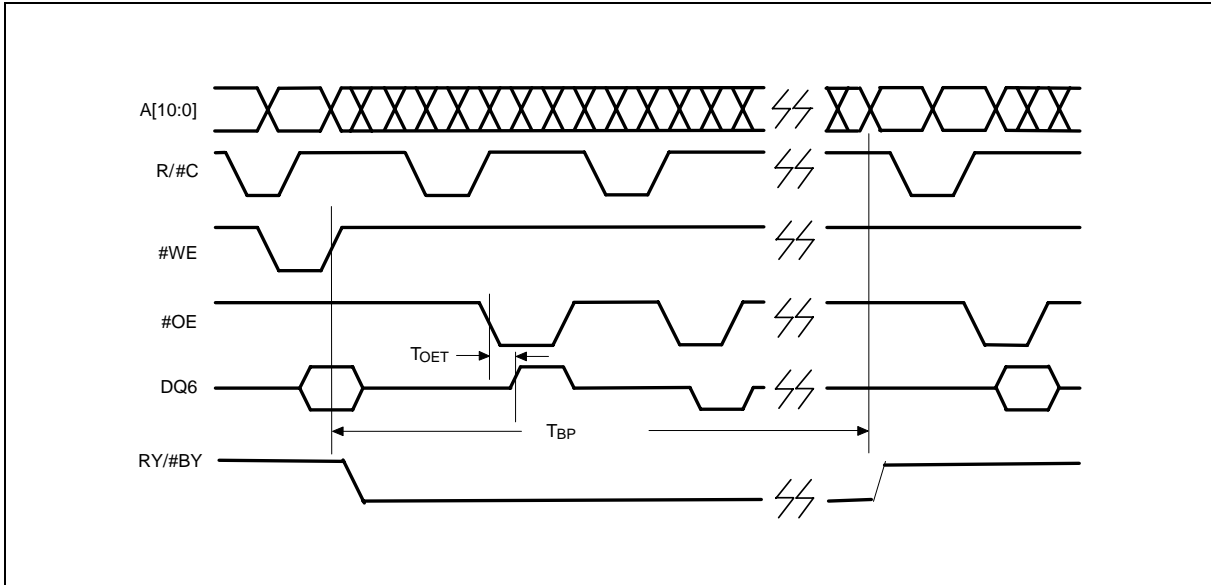

11.6 Sector Erase Timing Diagram

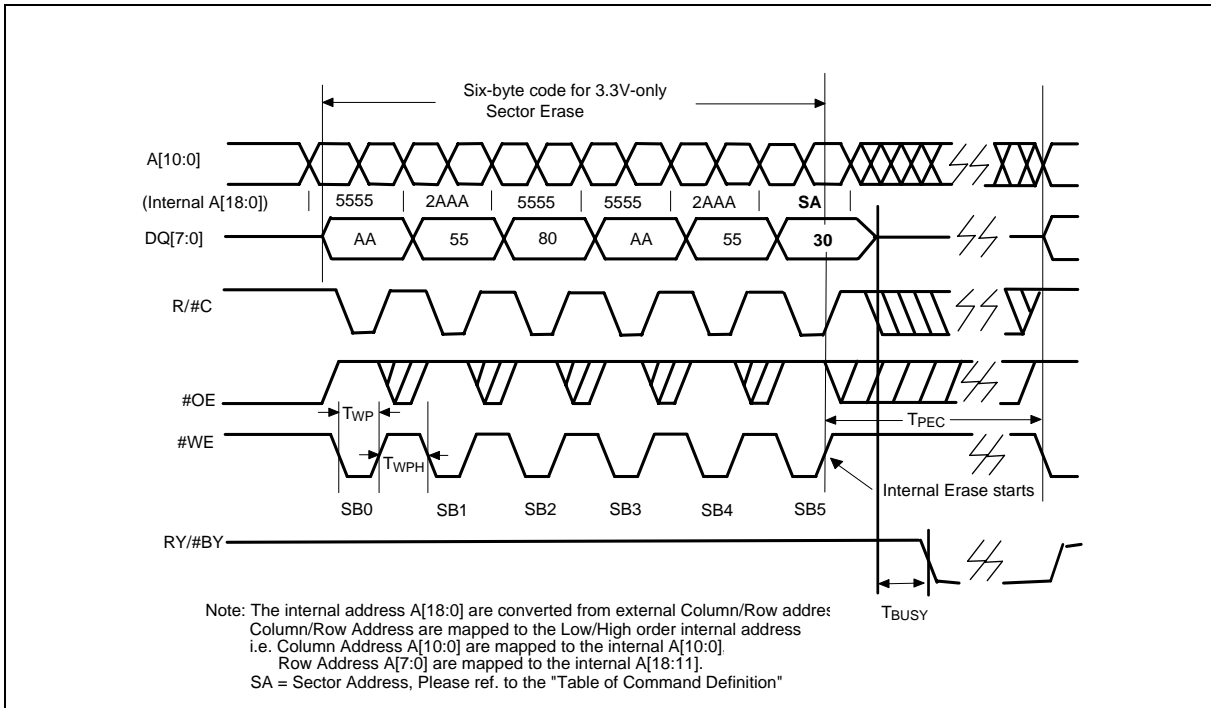



12. FWH INTERFACE MODE AC CHARACTERISTICS

12.1 AC Test Conditions

PARAMETER	CONDITIONS
Input Pulse Levels	0.6 V _{DD} to 0.2 V _{DD}
Input Rise/Fall Slew Rate	1 V/nS
Input/Output Timing Level	0.4V _{DD} / 0.4V _{DD}
Output Load	1 TTL Gate and C _L = 10 pF

12.2 Read/Write Cycle Timing Parameters

(V_{DD} = 3.3V ± 0.3V, V_{SS} = 0V, T_A = 0 to 70° C)

PARAMETER	SYMBOL	W39V040FB		UNIT
		MIN.	MAX.	
Clock Cycle Time	TCYC	30	-	nS
Input Set Up Time	TSU	7	-	nS
Input Hold Time	THD	0	-	nS
Clock to Data Valid	TKQ	2	11	nS

Note: Minimum and Maximum time have different load. Please refer to PCI specification.

12.3 Reset Timing Parameters

PARAMETER	SYMBOL	MIN.	TYP.	MAX.	UNIT
V _{DD} stable to Reset Active	TPRST	1	-	-	mS
Clock Stable to Reset Active	TKRST	100	-	-	μS
Reset Pulse Width	TRSTP	100	-	-	nS
Reset Active to Output Float	TRSTF	-	-	50	nS
Reset Inactive to Input Active	TRST	10	-	-	μS

Note: All AC timing signals observe the following guidelines for determining setup and hold times:

(a) High level signal's reference level is input high and (b) low level signal's reference level is input low.

Please refer to the AC testing condition.



13. TIMING WAVEFORMS FOR FWH INTERFACE MODE

13.1 Read Cycle Timing Diagram

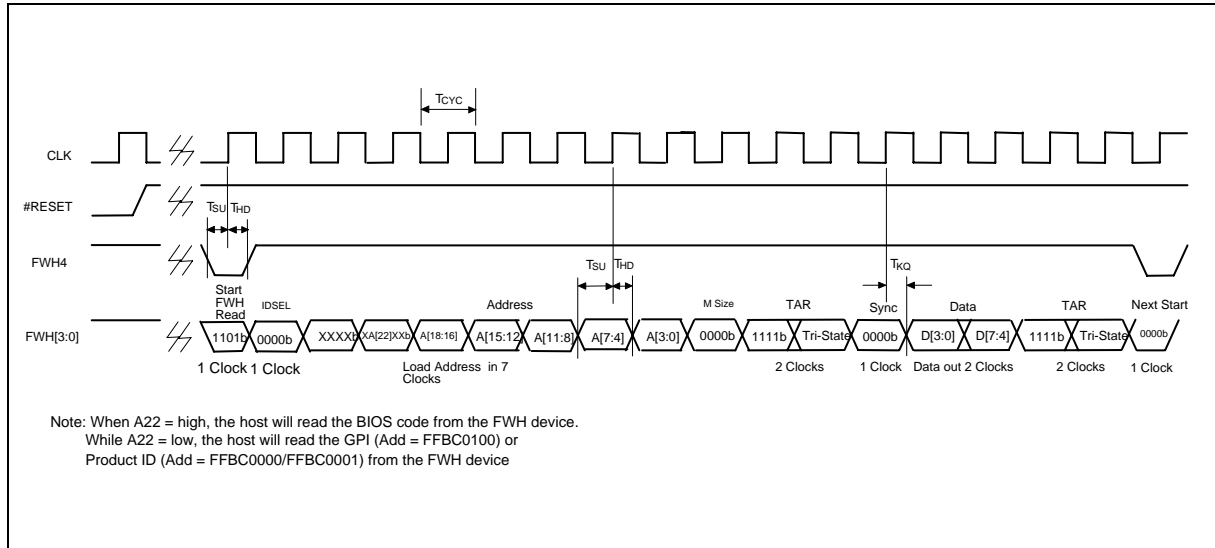

13.2 Write Cycle Timing Diagram

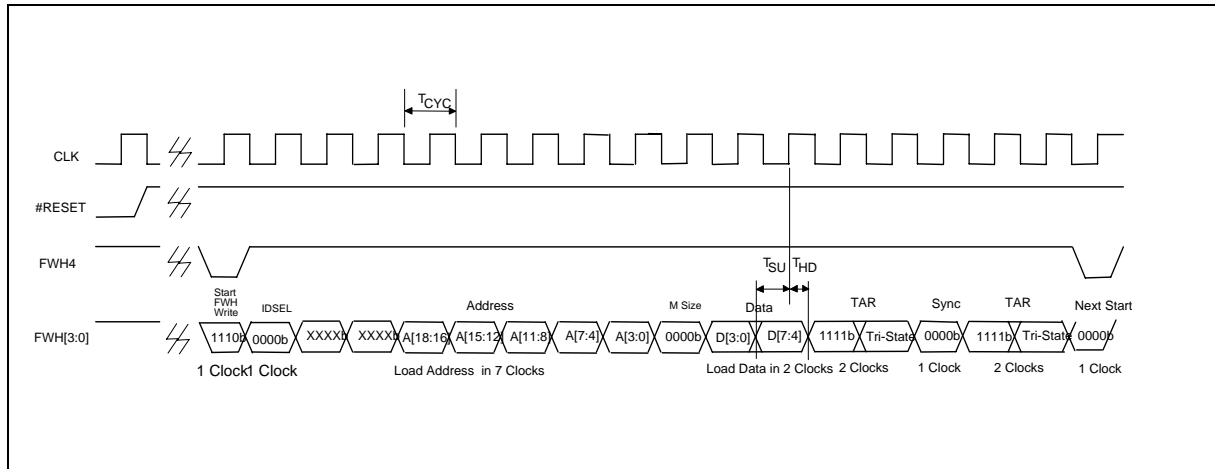



Timing Waveforms for FWH Interface Mode, continued

13.3 Program Cycle Timing Diagram

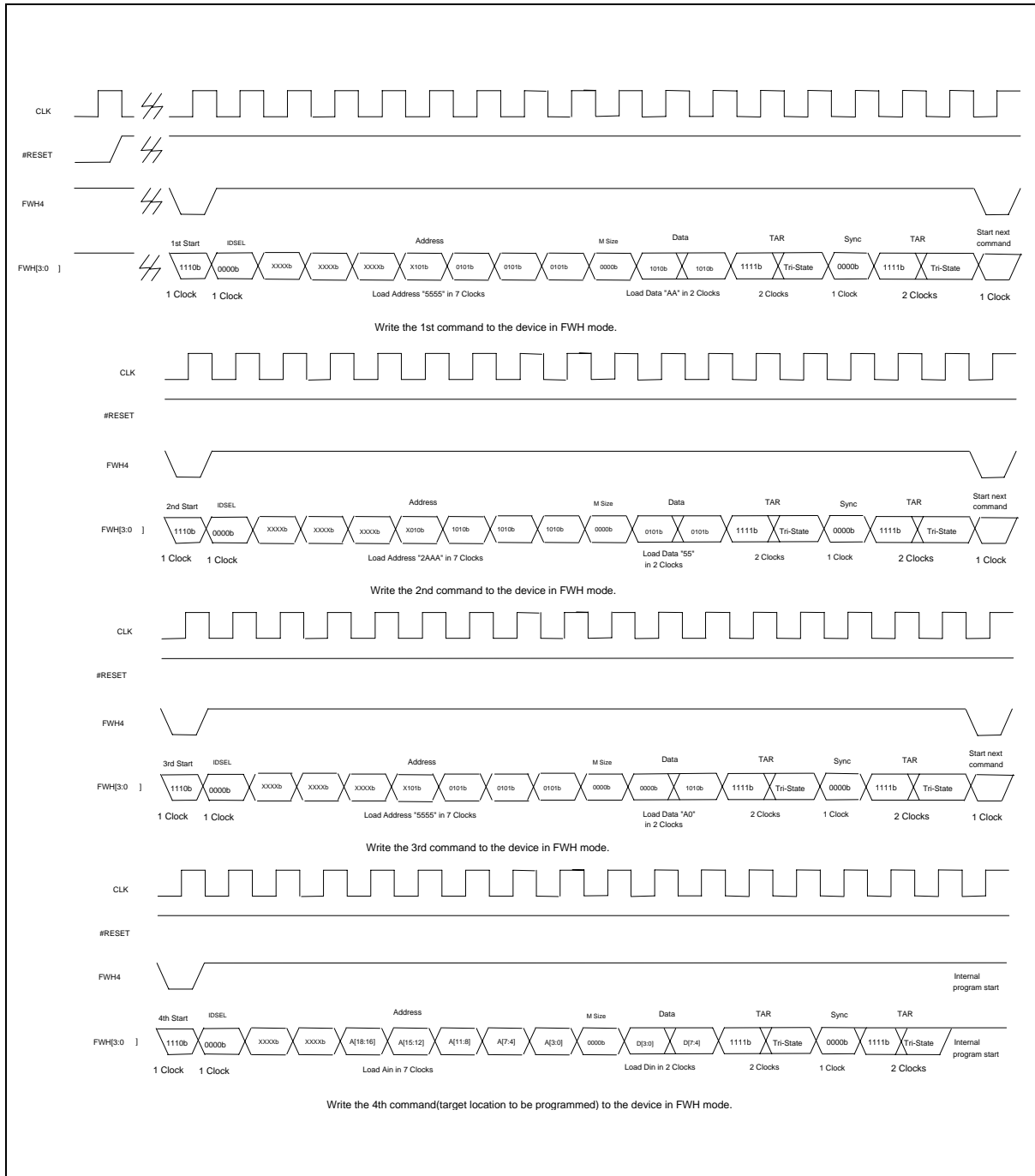



Timing Waveforms for FWH Interface Mode, continued

13.4 #DATA Polling Timing Diagram

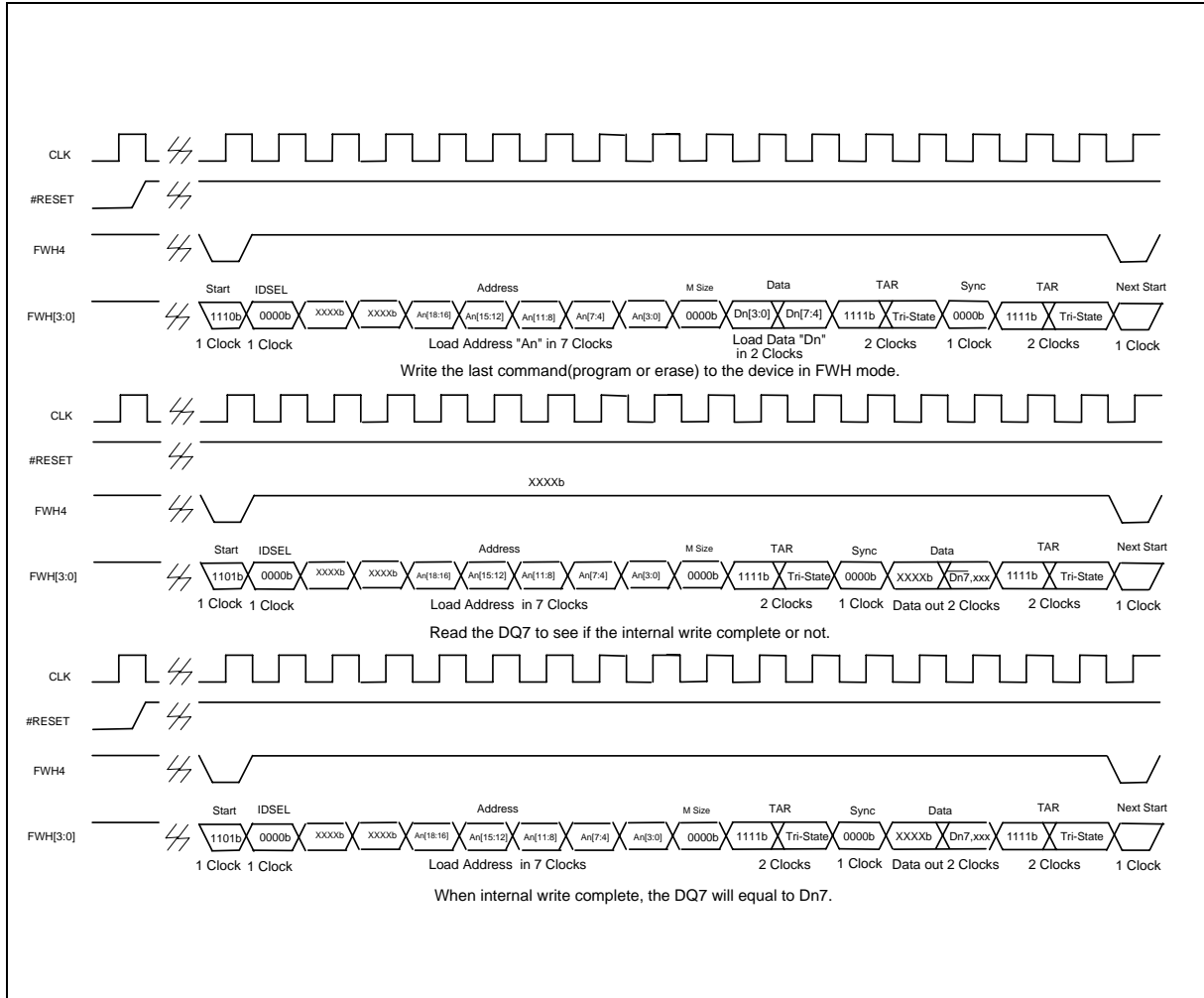



Timing Waveforms for FWH Interface Mode, continued

13.5 Toggle Bit Timing Diagram

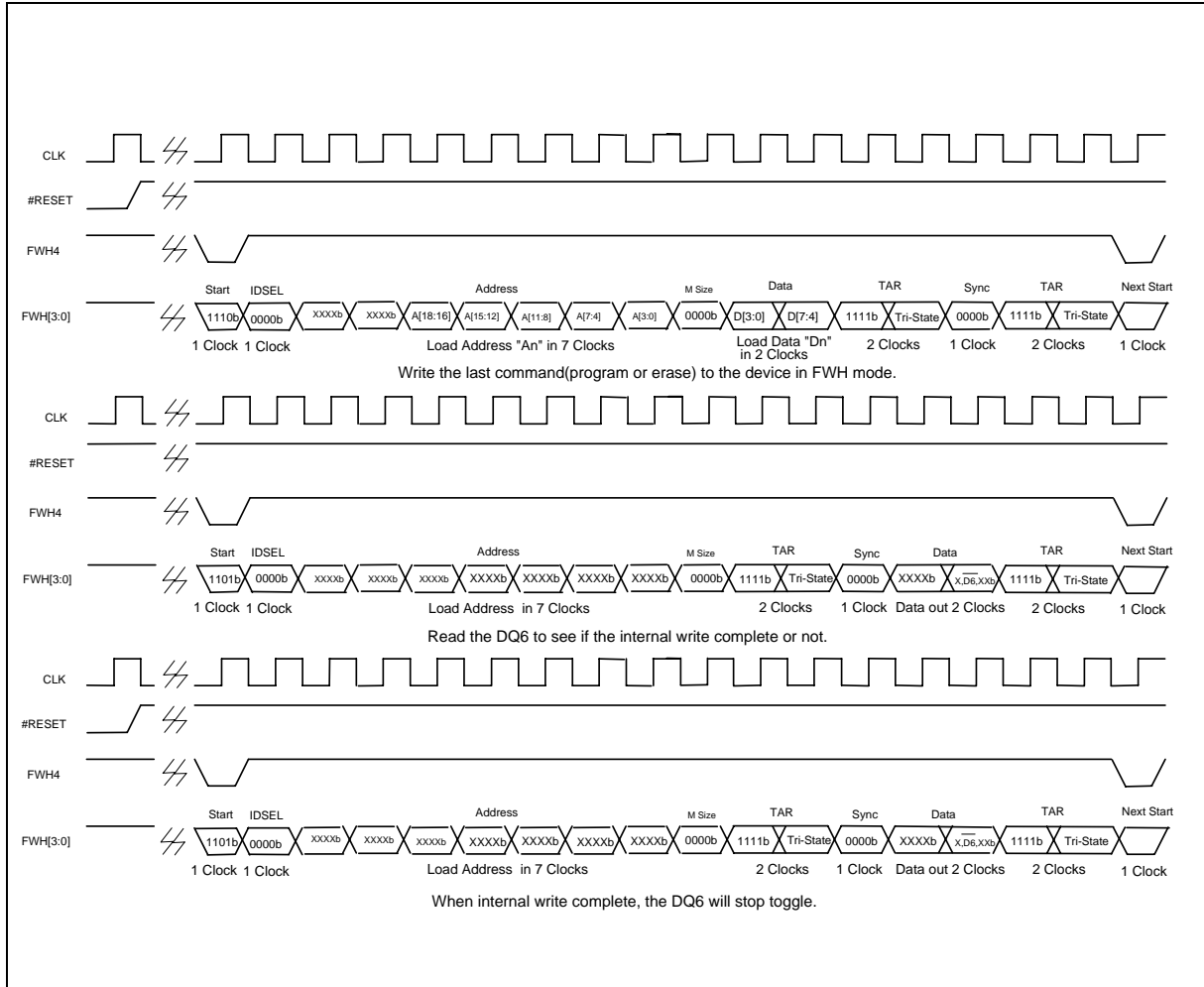



Timing Waveforms for FWH Interface Mode, continued

Sector Erase Timing Diagram

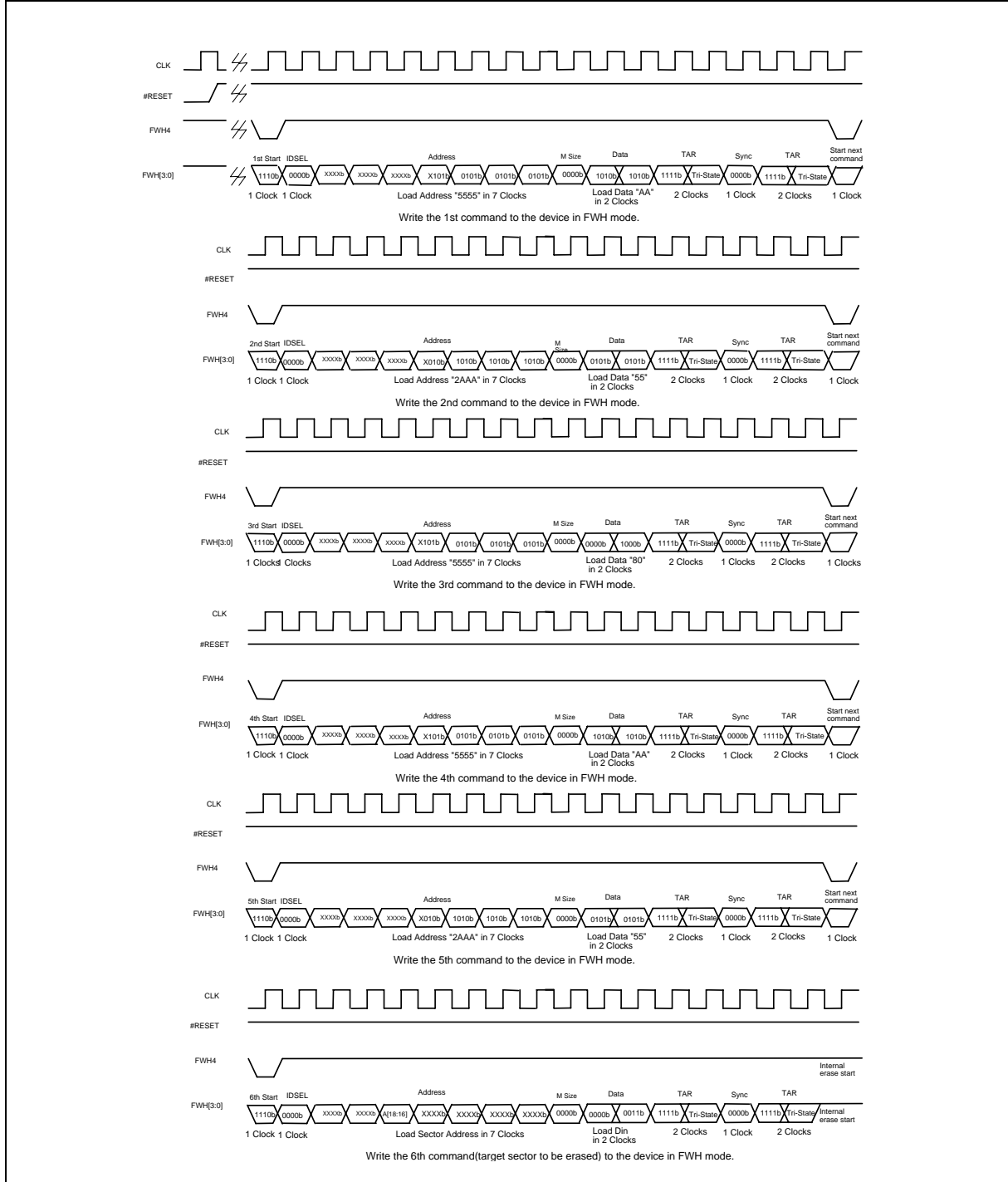



Timing Waveforms for FWH Interface Mode, continued

13.6 FGPI Register/Product ID Readout Timing Diagram

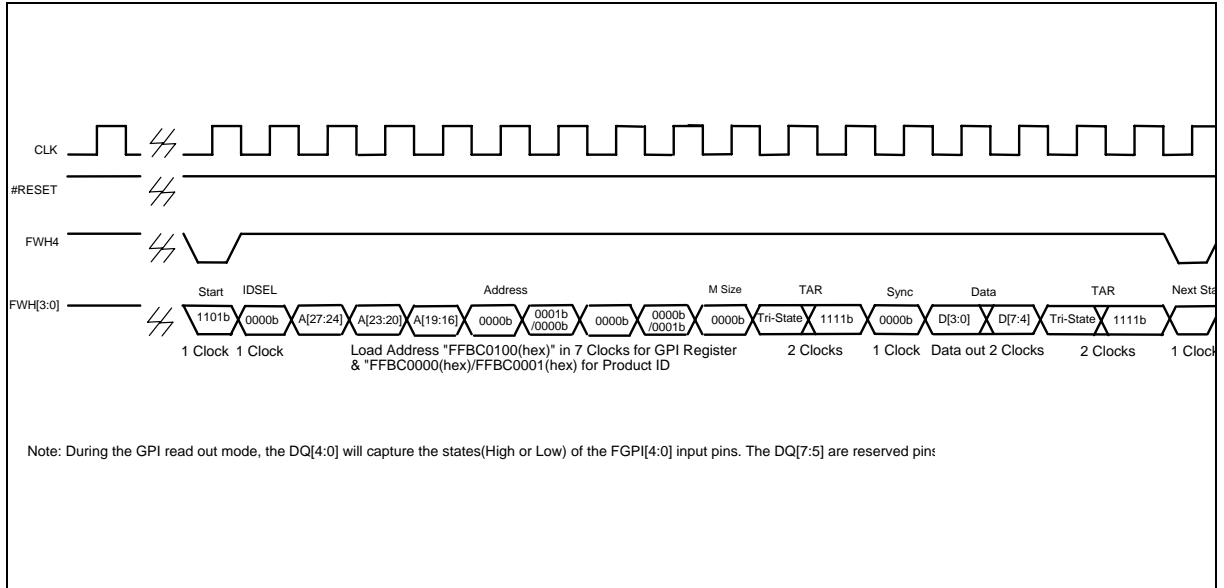

13.7 Reset Timing Diagram

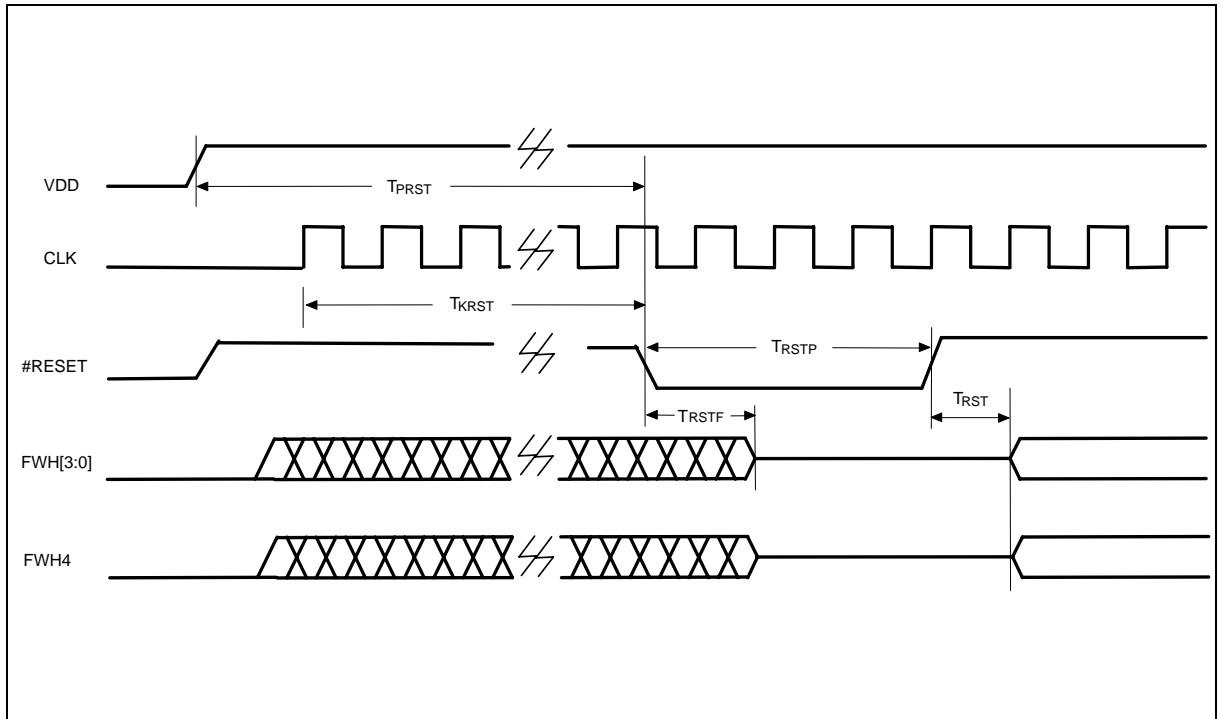

**14. ORDERING INFORMATION**

PART NO.	ACCESS TIME (nS)	POWER SUPPLY CURRENT MAX. (mA)	STANDBY VDD CURRENT MAX. (mA)	PACKAGE
W39V040FBP	11	30	10	32L PLCC
W39V040FBQ	11	30	10	32L STSOP
W39V040FBPZ	11	30	10	32L PLCC Lead free
W39V040FBQZ	11	30	10	32L STSOP Lead free

Notes:

1. Winbond reserves the right to make changes to its products without prior notice.
2. Purchasers are responsible for performing appropriate quality assurance testing on products intended for use in applications where personal injury might occur as a consequence of product failure.

15. HOW TO READ THE TOP MARKING

Example: The top marking of 32-pin STSOP W39V040FBQ



1st line: Winbond logo

2nd line: the part number: W39V040FBQ

3rd line: the lot number

4th line: the tracking code: 345 O B FA

149: Packages made in '03, week 45

O: Assembly house ID: A means ASE, O means OSE, ...etc.

B: IC revision; A means version A, B means version B, ...etc.

FA: Process code



16. PACKAGE DIMENSIONS

16.1 32L PLCC

Symbol	Dimension in Inches			Dimension in mm		
	Min.	Nom.	Max.	Min.	Nom.	Max.
A	—	—	0.140	—	—	3.56
A ₁	0.020	—	—	0.50	—	—
A ₂	0.105	0.110	0.115	2.67	2.80	2.93
b ₁	0.026	0.028	0.032	0.66	0.71	0.81
b	0.016	0.018	0.022	0.41	0.46	0.56
c	0.008	0.010	0.014	0.20	0.25	0.35
D	0.547	0.550	0.553	13.89	13.97	14.05
E	0.447	0.450	0.453	11.35	11.43	11.51
⊖	0.044	0.050	0.056	1.12	1.27	1.42
G _D	0.490	0.510	0.530	12.45	12.95	13.46
G _E	0.390	0.410	0.430	9.91	10.41	10.92
H _D	0.585	0.590	0.595	14.86	14.99	15.11
H _E	0.485	0.490	0.495	12.32	12.45	12.57
L	0.075	0.090	0.095	1.91	2.29	2.41
y	—	—	0.004	—	—	0.10
θ	0	—	10	0	—	10

Notes:

1. Dimensions D & E do not include interlead flash.
2. Dimension b₁ does not include dambar protrusion/intrusion
3. Controlling dimension: Inches
4. General appearance spec. should be based on final visual inspection sepc.

16.2 32L STSOP

Symbol	Dimension in Inches			Dimension in mm		
	Min.	Nom.	Max.	Min.	Nom.	Max.
A			0.047			1.20
A ₁	0.002		0.006	0.05		0.15
A ₂	0.035	0.040	0.041	0.95	1.00	1.05
b	0.007	0.009	0.010	0.17	0.22	0.27
c	0.004	-----	0.008	0.10	-----	0.21
D		0.488			12.40	
E		0.315			8.00	
H _D		0.551			14.00	
e		0.020			0.50	
L	0.020	0.024	0.028	0.50	0.60	0.70
L ₁		0.031			0.80	
Y	0.000		0.004	0.00		0.10
θ	0	3	5	0	3	5



17. VERSION HISTORY

VERSION	DATE	PAGE	DESCRIPTION
A1	August 19, 2004	-	Initial Issued
A2	October 4, 2004	3, 17, 18, 20	Modify lsb1, Tbp, Tpec, lcc (read) Add lcc (program/erase) and Toggle or polling interval Power supply voltage to Vss potential
A3	April 14, 2005	33	Add important notice
A4	Dec. 12, 2005	7, 16	Revise DQ5: Exceeded Timing Limits description, Embedded Toggle Bit Algorithm

Important Notice

Winbond products are not designed, intended, authorized or warranted for use as components in systems or equipment intended for surgical implantation, atomic energy control instruments, airplane or spaceship instruments, transportation instruments, traffic signal instruments, combustion control instruments, or for other applications intended to support or sustain life. Further more, Winbond products are not intended for applications wherein failure of Winbond products could result or lead to a situation wherein personal injury, death or severe property or environmental damage could occur.

Winbond customers using or selling these products for use in such applications do so at their own risk and agree to fully indemnify Winbond for any damages resulting from such improper use or sales.